



AIR COMMAND

AIR COMPRESSOR ACCESSORY KIT

INSTALLATION INSTRUCTIONS

Congratulations on your purchase of a new Ride-Rite Air Compressor Accessory Kit. This kit will be an asset to your vehicle, meeting nearly any of your air supply needs.

Please take a few minutes to read through the instructions, identify the components, and learn how to properly install your Air Compressor Accessory Kit.

NOTE:

If you are planning to install the Ride-Rite Fully Automatic control or Cab Control Height Adjustment systems, the Air Compressor Accessory Kit and the Ride-Rite air helper springs kit designed to fit your vehicle must first be installed. Contact Firestone for more information.

TOOLS REQUIRED:

- UTILITY KNIFE
- FLAT SCREW DRIVER
- WIRE CRIMPER/STRIPPER
- (2) 9/16" OPEN-END WRENCH
- 3/8" DRILL BIT
- ELECTRIC DRILL
- 1/2" WRENCH
- 3/8" WRENCH

PARTS LIST

COMPRESSOR	9285	1	PRESSURE SWITCH	1
AIR TANK	9124	1	COMPRESSOR T-FITTING	1
25 FT. EXTENSION HOSE	9006	1	TANK VALVE	1
3/8" -16 x 1" HEX BOLT		4	18 FT. AIR LINE TUBING	9038 1
3/8" -16 FLANGED HEX NUT		4	NYLON TIE	6
3/8" FLAT WASHER		4	15 FT. 16 GAGE WIRE WITH 1/4"	
10 -32 x 1" MACHINE SCREW		4	SPADE CONNECTOR	1
10 -32 NYLON-INSERT HEX NUT		4	QUICK-SPLICE CONNECTOR	1
3/16" FLAT WASHER		10	FEMALE SPADE TERMINAL	1
PUSH-TO-CONNECT			20 AMP BLADE FUSE	1
1/4 NPT MALE FITTING		1	FUSE HOLDER	1

Air Compressor Accessory Kit WR1-760-2047

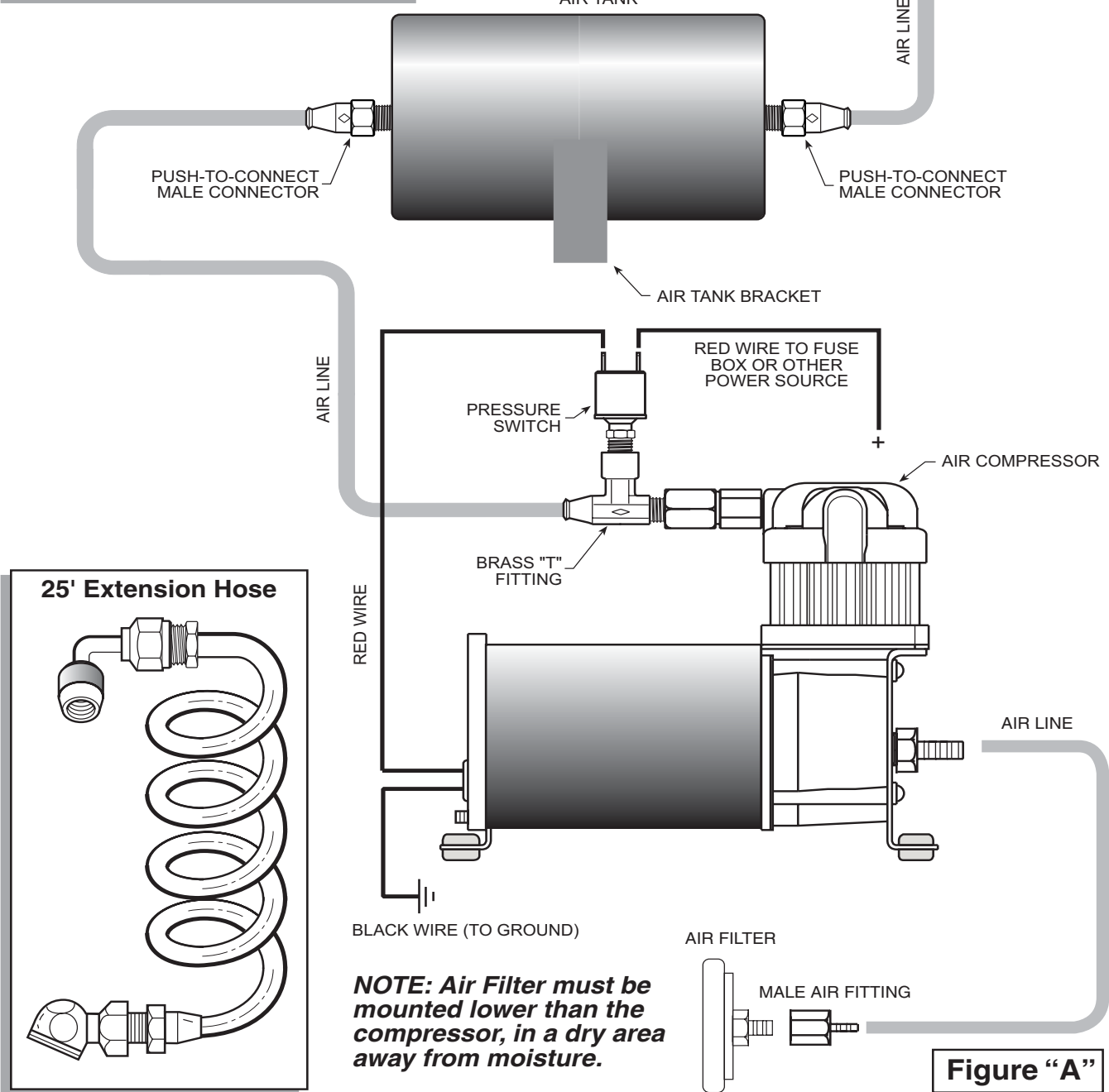
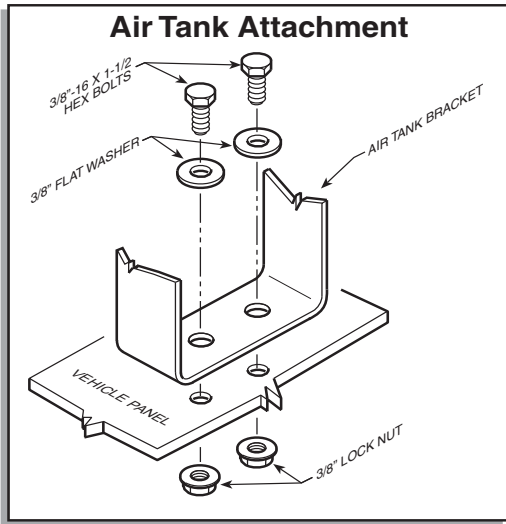

Figure "A"

NOTE ON CONNECTING AIR LINE TUBING

Cut the air line tubing as squarely as possible. To connect the air line tubing to the fittings push the tubing into the fittings as far as possible. If for any reason the tubing must be removed the collar of the fitting can be pushed toward the body of the fitting and the tubing can be removed. Make sure the air helper springs are deflated. To reassemble make sure the tubing is cut squarely and push back into the fitting.

STEP 1

Locate the brass "T" fittings as shown in *Figure "A"*. This fitting has a preapplied thread sealant on the male threads. No additional sealant is required.

Install the male threaded end into the compressor head as shown in *Figure "A"*. Tighten finger tight PLUS 3 1/2 turns. Next get the pressure switch from your hardware pack. Screw the pressure switch into the "T" fitting as shown in *Figure "A"*. Then attach the positive (RED) wire from the compressor to one of the terminals on the pressure switch. Install the rubber isolators and brass sleeves to the compressor feet (*see Figure "B"*).

STEP 2

Select a convenient location for mounting the compressor. This location should provide ample air flow and be protected from most airborne debris. The surface should be rigid to support the unit. Some examples might include under the hood on a fender well, or in a vented storage compartment. Mark and drill four 3/16" holes. It is recommended that burrs be removed from the holes so as not to damage the rubber isolator. Mount the compressor using the #10 pan head machine screws and #10 flat washers located in your hardware pack. Assembly of the flat washers, machine screws, and lock nut are shown in *Figure "B"*.

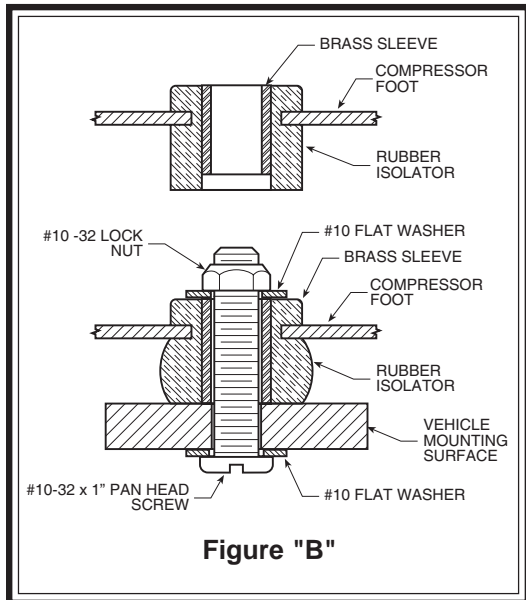

Figure "B"

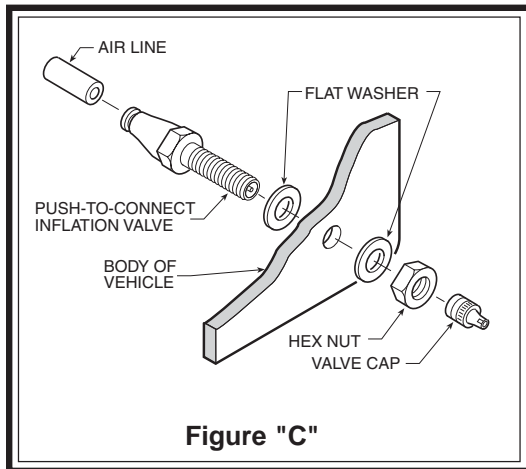

Figure "C"

Proper mounting of this compressor will provide maximum isolation. *Figure "B"* shows the before and after condition of the rubber isolator. The screw and nut should be tightened only enough to bottom out on the brass insert. **DO NOT OVER TIGHTEN** further tightening will crush the insert and isolator and reduce vibration isolation.

Attach the black wire from the compressor to a convenient ground source on the vehicle. Most any metal connection point common to the vehicle frame should be suitable.

STEP 3

Get the air tank and mount two 1/4" NPT male connectors into the air tank ports (*see Figure "A"*).

Select a location for mounting the air tank. This location should be protected to prevent damage from flying rocks or debris. Mark and drill two 7/16" holes 2-1/2" apart. Bolt the tank in place using the 3/8"-16 x 1-1/2" hex bolts, washers and lock nuts provided. Be sure clear access is provided to the two air ports. (SEE CAUTION NOTE).

CAUTION:

The air tank supplied with this kit should be protected. Dents or punctures could cause air leaks, personal injury or property damage. Do not exceed 120 psi in the tank.

STEP 4

Measure a length of air line tubing to go from the compressor to the tank and cut as squarely as possible. A ragged or angled cut can cause a leak in the system. **Do not fold or kink the air line tubing.**

STEP 5

Select a point on your vehicle for the inflation valve. This should be a rigid surface, easily accessible and convenient (examples might be a wheel well or bumper). Drill a 5/16" hole and install the inflation valve as shown in *Figure "C"*. Tighten the inflation valve securely and replace the cap.

NOTE: The cap should always be replaced to protect the inflation valve from dirt and debris.

STEP 6

Measure a length of remaining air line tubing to run from the tank to the inflation valve. Cut as squarely as possible and install according to previous directions.

NOTE: We have provided 18 feet of air line tubing in this kit. Should your installation require more, or your tubing becomes damaged, you should use 1/4" DOT approved nylon air brake tubing. This is available at most truck parts dealers.

STEP 7

Get the red wire supplied in your hardware pack. This wire has attached to one end a 1/4" spade connector. Attach this connector to the remaining stud on the compressor pressure switch. The other end of the wire is to be attached to a positive 12 Volt D.C. supply capable of handling 20 amps. It is recommended that the connection be made to an ignition controlled circuit. This method of connection will provide power to the compressor only when the key is on. Consult your dealer or vehicle owners manual for proper fuse box connection.

Should you desire a circuit which is not ignition switch controlled a switch should be placed in the system. Make sure the automotive switch you purchase is capable of 20 amps minimum. Turning the switch off when the compressor is not needed will prevent the compressor from operating periodically and draining the battery. Consult your dealer or vehicle owners manual for wiring diagrams.

NOTE: Should additional wire be necessary, use 16 gage multistrand wire.

YOU ARE NOW READY TO TEST THE SYSTEM

Turn on the ignition. The air compressor will run for a short time to build up pressure in the tank. Once this air pressure reaches approximately 120 psi in the air tank, the pressure switch will turn the compressor off. It will not restart until the pressure in the tank drops below 90 psi.

USING YOUR RIDE-RITE AIR COMPRESSOR ACCESSORY KIT

Your system is now ready to use. With the coiled tubing provided, attach the end with the screw style fitting to the inflation valve. You can now use the air chuck on the opposite end to inflate Ride-Rite air helper springs, tires, air shocks and many other items.

FILTER MAINTENANCE PROCEDURE

It is recommended that the air compressor filter be inspected periodically. The frequency that the inspection should occur depends on how often the compressor is being used. The air compressor filter is located on the head of the compressor opposite the "Tee" air fitting. If the filter is sufficiently clogged it will require replacement. A used filter should not be cleaned or reused. A replacement filter is supplied with your kit.



LEVEL COMMAND TEMPLATE SHEET

Cut out template and trace on dash mount location.

This template represents actual size of cut

Fig. F

