

STEP 7 BOLT TIGHTENING SEQUENCE

- Make sure that the sideplates are tight against the under side of the frame, then tighten the 5/8" nuts on each sideplate to 90 ft. lbs.
- Tighten the 1/2" bolts & nuts on each sideplate to 80 ft. lbs.
- While holding the pin brackets toward the inside of the frame tighten the two bolts on each side to 80 ft. lbs. There may be a small space between the brackets and frame on some trucks.
- Tighten the four front and four rear center section bolts to 80 ft. lbs.

STEP 8 INSTALL LATCH PIN RELEASE HANDLE

WARNING: LATCH PIN WILL NOT FUNCTION PROPERLY IF HANDLE IS NOT INSTALLED CORRECTLY.
Install the handle from underneath the truck by inserting it through the slot in the end of the center section toward the driver's side rear tire as shown. Attach the handle to the latch pin as shown with the handle on the "cab side" of the square tab welded to the pin. The head of the bolt must be on the handle side, and the lock nut must be on the tab side. The tab is welded to the pin in an offset position so that the handle will be lined up over the center of the pin. If the handle is fastened to the other side of the tab, the handle will not function properly. When installed correctly the latch pin may be disengaged from the ball by pulling on the handle from the driver's side wheel well and rotating the handle clockwise.

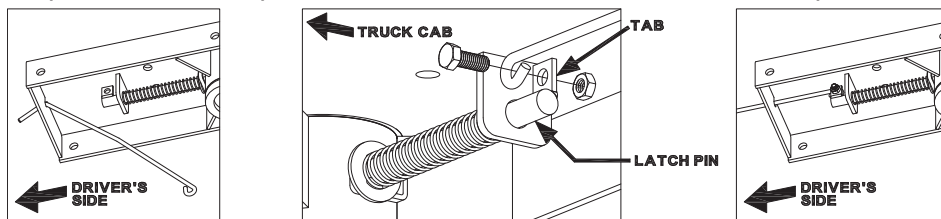

STEP 9 INSTALL SAFETY CHAIN BRACKETS



To install the safety chain brackets it is necessary to drill four 1/2" holes through the truck bed floor. Locate the four holes that will allow the Safety Chain U-bolts to set down in the low part of the truck bed rib after installed. This can be different from model to model. Because of room restraint it may be necessary to drill a small pilot hole from the under side and then drill the 1/2" holes from the top. Drop a U-bolt through each pair of holes from the top side of the truck bed floor. Place a conical spring on each leg of the U-bolts with the larger opening of the spring toward the center section. Next place a lock nut on each bolt leg and tighten until flush with the bottom of the bolt.

STEP 10 REINSTALL FUEL VALVE CANISTER AND INNER FENDER GUARDS

The fuel valve canister (if removed) can now be bolted back into its original position. However the vent hose will no longer go into the same hole. Place the open end of the vent hose between the bed cross member and the rear hitch cross member and push in as far as possible. This can be secured with a wire tie or tape if necessary. This new location will put the vent into the same environment as the old location. Replace the inner fender guards in the reverse order of removal.



STEP 11 ENGAGE LATCH PIN

Retract the latch pin by pulling the handle all the way out and rotating it clockwise. Place the turnover ball in the hitch receiver. Engage the latch pin by moving the handle to the right and in. Be certain the latch pin passes through the hole and the Turnover Ball and fully engages through the hitch receiver. Repeat this process with the Turnover Ball in all eight positions. Grease the square base of the Turnover Ball.



B&W Trailer Hitches

1216 HWY 224 / PO Box 186
Humboldt, KS 66748
800.248.6564
620.473.3664
Fax:620.473.3766

**Call or Email us for
Installation Support**

hitches@turnoverball.com
www.turnoverball.com

NOTE: We recommend reading instructions before beginning the installation.

Turnover Ball™ Gooseneck Hitch Installation Instructions

Model 1208R

2004 - 2010 Nissan Titan All Beds

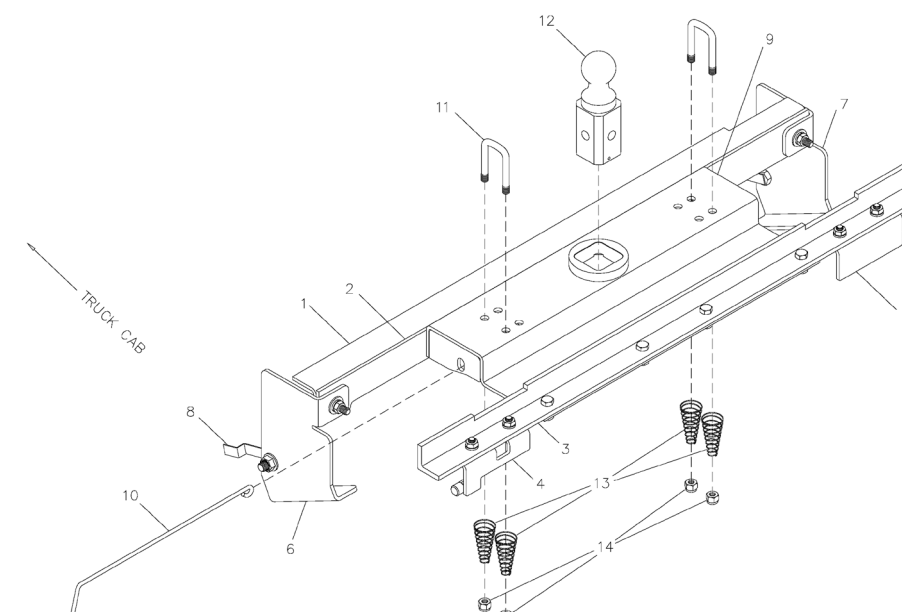

PARTS LIST

- FRONT CROSS MEMBER
- FRONT CROSS MEMBER BRACE
- REAR CROSS MEMBER
- DRIVER'S SIDE PIN BRACKET
- PASS. SIDE PIN BRACKET
- DRIVER'S SIDE SIDEPLATE
- PASS. SIDE SIDEPLATE
- BOLT GUIDE ASSEMBLY
- CENTER SECTION
- HANDLE
- SAFETY CHAIN U-BOLTS
- TURNOVERBALL
- SPRINGS
- 1/2" LOCK NUTS

Hardware Kit

- 2 ea. - Bolt Guide Assembly
- 2 ea. - 5/8" Flange Nuts
- 6 ea. - 1/2" x 2" Carriage Bolts
- 8 ea. - 1/2" X 1 1/2" Hex Cap Screw
- 14 ea. - 1/2" Finish Nut
- 10 ea. - 1/2" Flat Washer
- 14 ea. - 1/2" Split Lock Washer

Safety Chain Kit

- 2 ea. - 1/2" U-bolts
- 4 ea. - Springs
- 4 ea. - 1/2" Lock Nuts
- 1 ea. - 3/8" X 3/4" Hex Cap Screw
- 1 ea. - 3/8" Center Lock Nut

BEFORE INSTALLING OVERHEAD LIFTING DEVICE

An overhead-lifting device, such as chain falls, engine hoist, or cable come-a-long, can be used to lift the center section of the hitch in place. Lower a loop of rope or chain through the 4" hole in the truck bed floor and attach it to the latch pin in the round hitch receiver tube in the center section. Use the lifting device to raise the center section until the round hitch receiver tube that protrudes from the center section fits in the 4" hole in the truck bed floor. Maintaining upward pressure may facilitate fastening the crossmember to the center section, especially if the truck bed floor has been distorted downward from heavy use. If you use an overhead-lifting device, it should be disconnected before squaring the center section across the frame, installing the sideplates and torquing fasteners.

WARNING

Most trucks have FUEL LINES and/or BRAKE LINES and/or ELECTRICAL WIRES located along the frame rails where B&W Turnover Ball hitches install. Carefully examine the location of fuel lines, brake lines and electrical wires BEFORE INSTALLATION. Be certain you will not damage fuel lines, brake lines or electrical wires when positioning hitch components, drilling holes, tightening fasteners, and lifting and lowering the truck bed. The fuel tank vent, located on top of the gas tank, can be easily damaged during the installation of the hitch components. Care must be taken when positioning the front crossmember and center section components.

CLEARANCE WARNING

On Short bed trucks, BEFORE INSTALLING THIS HITCH, check for adequate turning clearance between the front of all of your trailers and the truck cab.

WARNING

DO NOT invert the ball in the socket when carrying heavy loads on 2 wheel drive trucks. The ball may hit the top of the differential. Remove the ball from the socket before loading. A plug for the socket is available from B & W.

WARNING

The tow vehicle manufactures recommended towing capacities should Under **NO** Circumstances be exceeded.

INSTALLATION INSTRUCTIONS

STEP 1 REMOVE SPARE TIRE, HEAT SHEILD, FUEL VALVE CANISTER, AND INNER FENDER GUARDS

A) The heat shield under the bed floor must be removed before the hitch can be installed. This is done by removing the eight screws that hold the heat shield to the bed cross members using a 10MM. wrench, then slide the heat shield toward the rear of the truck and remove. The heat shield can be discarded, the hitch will replace this section of the heat shield.



B) Using a small screwdriver remove the vent hose from the bed cross member. Locate the rectangle shaped fuel valve canister. If it is mounted behind the tube frame cross member it will not interfere with the installation. If it is mounted in front of the tube frame cross member it will need to be lowered during the installation. First remove the 3 small bolts that hold the canister bracket to the truck using a 10MM. wrench. Then slide the canister toward the center of the truck far enough to allow the end toward the frame to be pulled downward. Then slide the canister back toward the frame to allow the complete canister to drop down about 4 to 5 inches this will be enough room to complete the installation.



C) The inner fender guards toward the front of both rear fender wells will need to be removed to allow the installation of the hitch side plates. This is done by removing two screws and sliding the guard toward the tire. These guards will be replaced in step 10.

STEP 2 MARKING AND CUTTING THE 4 INCH HOLE

Measure from the back end (tail gate end) of the truck bed floor by hooking a tape measure over the end of the bed and marking the floor at 46 1/2". Using a tape measure find the center of the bed floor between the fender wheel wells, this will be the center point of the 4 inch hole.

These locations are critical for the correct installation of this hitch, so measure, mark, and saw carefully. Make a 4" hole in this location using a 4" hole saw, or by marking a 4" circle and cutting it out with a saber saw equipped with a metal cutting blade.



2008 - ALL BEDS --- 46 1/2"

STEP 3 INSTALL REAR CROSSMEMBER AND PIN BRACKETS

Before the rear cross member can be installed there must be two small notches cut in the bed floor flange behind the center bed cross member on the passenger side. At 2" behind the center cross member make the first V-shape notch 1/2" tall x 1" wide in the bed floor flange. The second notch will need to be 2 1/4" behind the first.

(see diagram)

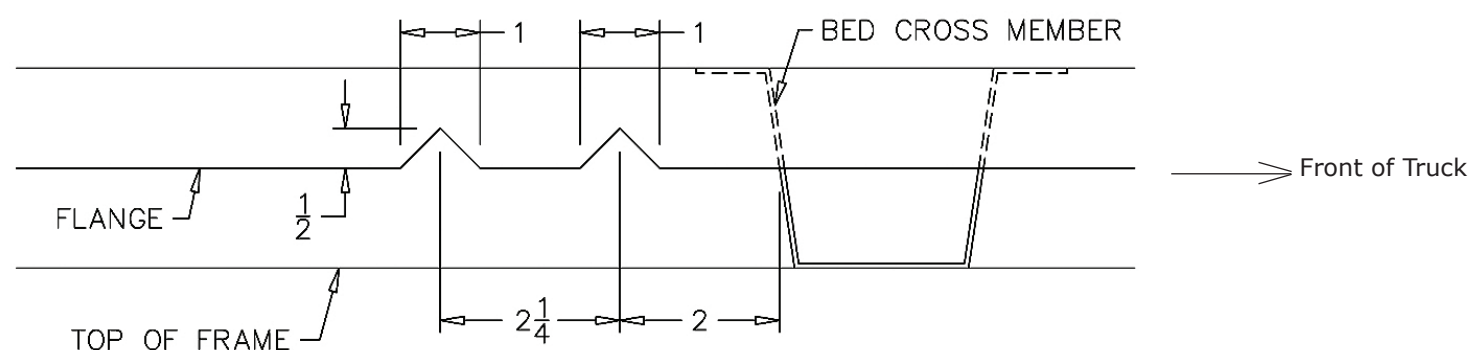

After cutting the notches the rear cross member can be installed using the two notches to accept the legs of the cross members. The rear crossmember can be identified as the 2" x 2" angle with two cut outs on one of the legs. Slide the angle across the top of the frame using the two notches's to accept the legs of the crossmember with the leg containing the two cut outs toward the front of the truck. Center the cross member on the top of the frame. Next turn the crossmember so that the two cut outs are toward the bed floor and the crossmember leg that contains the holes will lay flat on top of the frame. Next install the pin brackets on each side of the cross member. The mounting kit contains a driver side and passenger side pin bracket. The driver's side can be identified by having a notch cut in it for clearance of a fuel canister tube on some models. When they are installed correctly the pin will be in the hole on the inside of the frame and the bolt holes will face up and forward and align with the two outside holes on each end of the rear cross member. Place a 1/2" x 1 1/2" bolt with a lock washer and nut in the four holes that bolt the pin brackets to the rear cross member.



Do not fully tighten at this time.

STEP 4 INSTALL CENTER SECTION



Install the center section by raising it up between the frame on the passenger side of the truck and the exhaust pipe. At the same time turn it flat and slide it over the gas tank, making sure that the spring loaded latch pin assembly is toward the driver's side of the truck. With the center section in the center of the truck slide it toward the rear placing the flat part of the center section that has 4 slotted holes in it between the bed cross member and the round frame cross member. Slide it back until the slotted holes align with the holes in the rear cross member. Install a 1/2" x 1 1/2" bolt through the rear cross member and the slotted holes in the center section and place a flat washer, lock washer and nut on the bolts.

Do not fully tighten at this time.

STEP 5 INSTALL FRONT CROSS MEMBER AND BRACE

Install the cross member brace between the frame and truck bed from the driver's side. The cut out area should be facing down and toward the driver's side. This will allow clearance for the fuel tank on some models. Slide it back toward the center section. Next install the front cross member. Slide the end with the short notch between the frame and truck bed from the driver's side. The notch should be facing up and toward the front of the truck. This will allow clearance around the shock bracket on the passenger side when fully installed. With the cross member and brace spanning the frame slide both back against the center section. Install a 1/2"x2" carriage bolt through the cross member and brace on the passenger side just behind the shock bracket. This will be used later.

While pushing up on the center section (so the socket top fits through the four inch hole in the truck bed) align the holes and install the carriage bolts through the cross member, brace and then the center section. Place a flat washer, lock washer, and nut on each bolt. **Do not fully tighten at this time.**

STEP 6 INSTALL SIDEPLATES

Before the passenger side sideplate can be installed a wiring harness must be moved. This can be done by pulling the two push in connectors out of the frame directly under the shock bracket on the outside of the frame. Lift the harness up and over the front cross member. The sideplate when installed will hold it in this location.

The side plate with the decal goes on the driver's side. Place it against the frame with the bent ear with the slotted hole facing inward just behind the cross members. Place a carriage bolt through the cross member, brace and the side plate ear secure with a flat washer, lock washer, and nut. The bottom of the sideplate should face in and match the slope of the under side of the frame when installed properly. Place one of the bolt guide assemblies (bolt first) through the larger oval hole just in front of the sideplate, twisting it around and back out through the smaller hole in the frame and sideplate. Use the tab on the end of the bolt guide assembly to hold in place while a 5/8" flange nut is installed. Repeat this on the passenger side. The passenger side sideplate may not lay perfectly flat against the frame because of the shock bracket that is welded on. This will cause no problems with the fit or function of the hitch.